

REVISIONS					
ZONE	LTR	DESCRIPTION	1112	DATE	APPROVED
	H	MODIFIED PRINT PER MARK-UP	ECN0025546 GML	12-20-05	D.M.

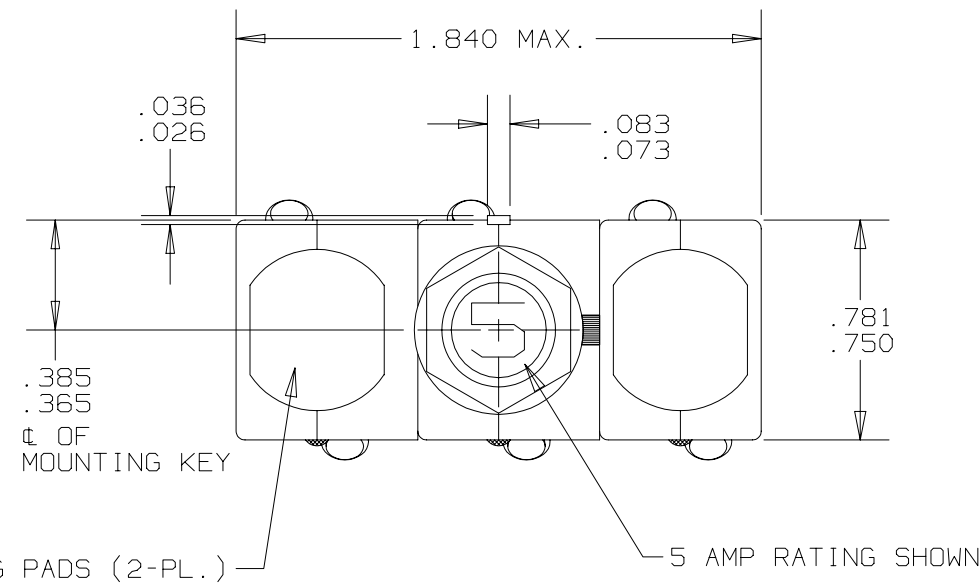

PERFORMANCE CHARACTERISTICS

DETAIL PERFORMANCE PER MIL-C-5809

OVERLOAD CYCLING	-----	100 CYCLES AT 200% RATING
VIBRATION	-----	10 G'S MINIMUM 50-500 HZ
MECHANICAL SHOCK	-----	50 G'S
ACCELERATION	-----	10 G'S
SAND AND DUST	-----	12 HOURS
CORROSION	-----	SALT SPRAY 50 HOURS
HUMIDITY	-----	10 DAYS
EXPLOSION PROOF	-----	WHILE INTERRUPTING RUPTURE CURRENTS

ENDURANCE:	120 VAC	400 HZ INDUCTIVE	2500 CYCLES
		400 HZ RESISTIVE	5000 CYCLES
		NO LOAD	5000 CYCLES

SINGLE * OR THREE PHASE CALIBRATION:	2 AMP THRU 20 AMP				
	MIN. ULT. TRIP	MAX. ULT. TRIP	200%	500%	1000%
+25°C, +77°F	110% RATING	145% RATING	4-20 SEC.	.40-2.0 SEC.	.10-.53 SEC.
-55°C, -65°F	110% RATING	165% RATING	6-40 SEC.	.55-3.5 SEC.	.15-.80 SEC.
+71°C, +160°F	100% RATING	145% RATING	3-20 SEC.	.33-1.7 SEC.	.08-.40 SEC.

RUPTURE:	2 AMP THRU 20 AMP	120 VAC, 400 HZ	2000 AMPS
----------	-------------------	-----------------	-----------

MAXIMUM OPERATING FORCES	
PULL OUT	----- 12 LBS. MAX. (53.4 N)
RESET	----- 12 LBS. MAX. (53.4 N)

OPERATING ALTITUDE: 70,000 FT. (21,000 M)

WEIGHT: 65.0 GRAMS MAX. (.143 LBS.)

VOLTAGE DROP:	
2 AMP	----- 0.70 VOLTS MAX.
2.5 AMP	----- 0.50 VOLTS MAX.
3 AMP	----- 0.40 VOLTS MAX.
4 AMP	----- 0.37 VOLTS MAX.
5 AMP	----- 0.35 VOLTS MAX.
7.5 AMP	----- .192 VOLTS MAX.
10 AMP	----- .176 VOLTS MAX.
15 AMP	----- .176 VOLTS MAX.
20 AMP	----- .176 VOLTS MAX.

* SINGLE PHASE MAXIMUM ULTIMATE TRIP VALUES APPLY WITH OTHER TWO PHASES CARRYING 100% OF RATED CURRENT

NOTES:

1. EPOXY SURFACES ARE NON-DIMENSIONED. ENVELOPE DRAWING DIMENSIONS DO NOT APPLY TO THESE PROJECTED EPOXY SURFACES.
2. TERMINAL AND MOUNTING HARDWARE MAY BE PACKAGED RATHER THAN INSTALLED.
3. COUNTRY OF ORIGIN IS SHOWN FOR ILLUSTRATION PURPOSES ONLY. COUNTRY OF ORIGIN TO BE IDENTIFIED AS REQUIRED.
4. DATE CODE PER 10588-285.
5. ALL MARKINGS TO BE MADE IN APPROXIMATE POSITIONS SHOWN WITH BLACK INK PER 12506-70. 3/32 HIGH CHARACTERS.

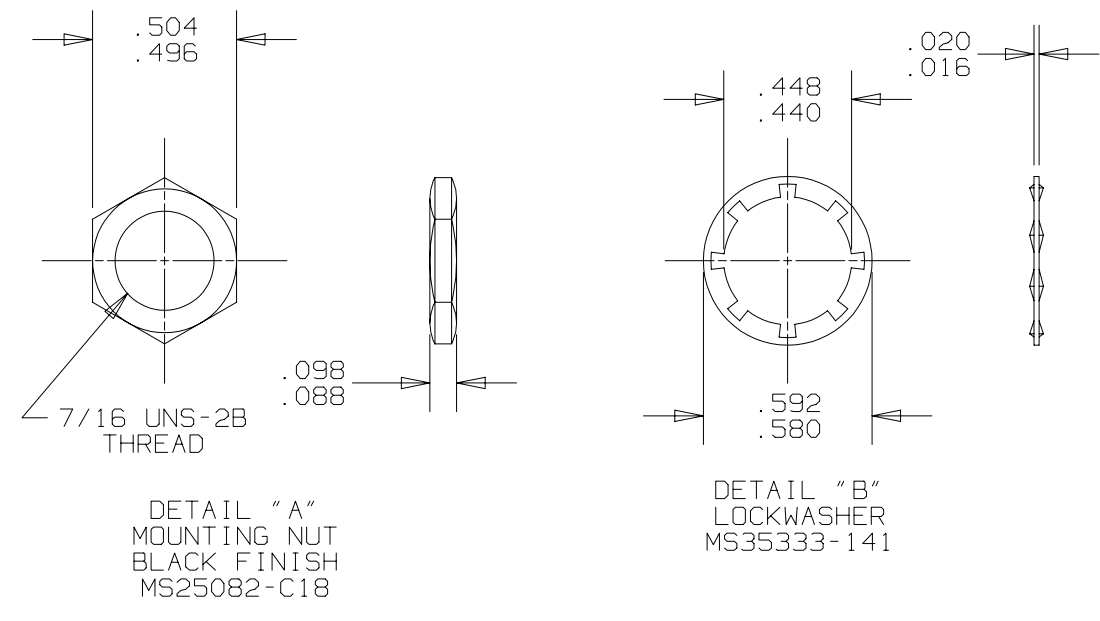
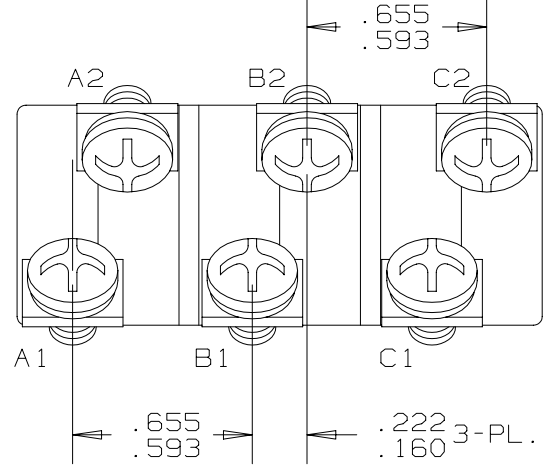
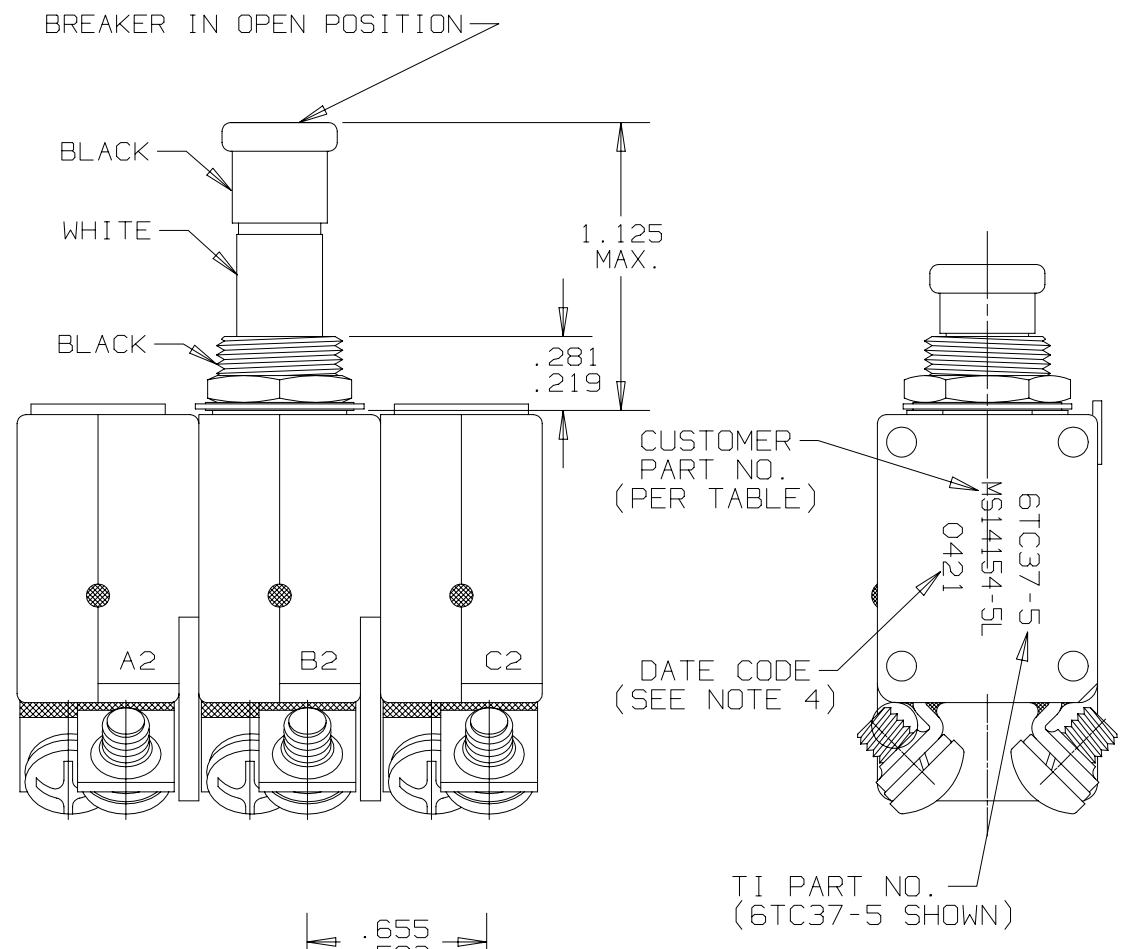
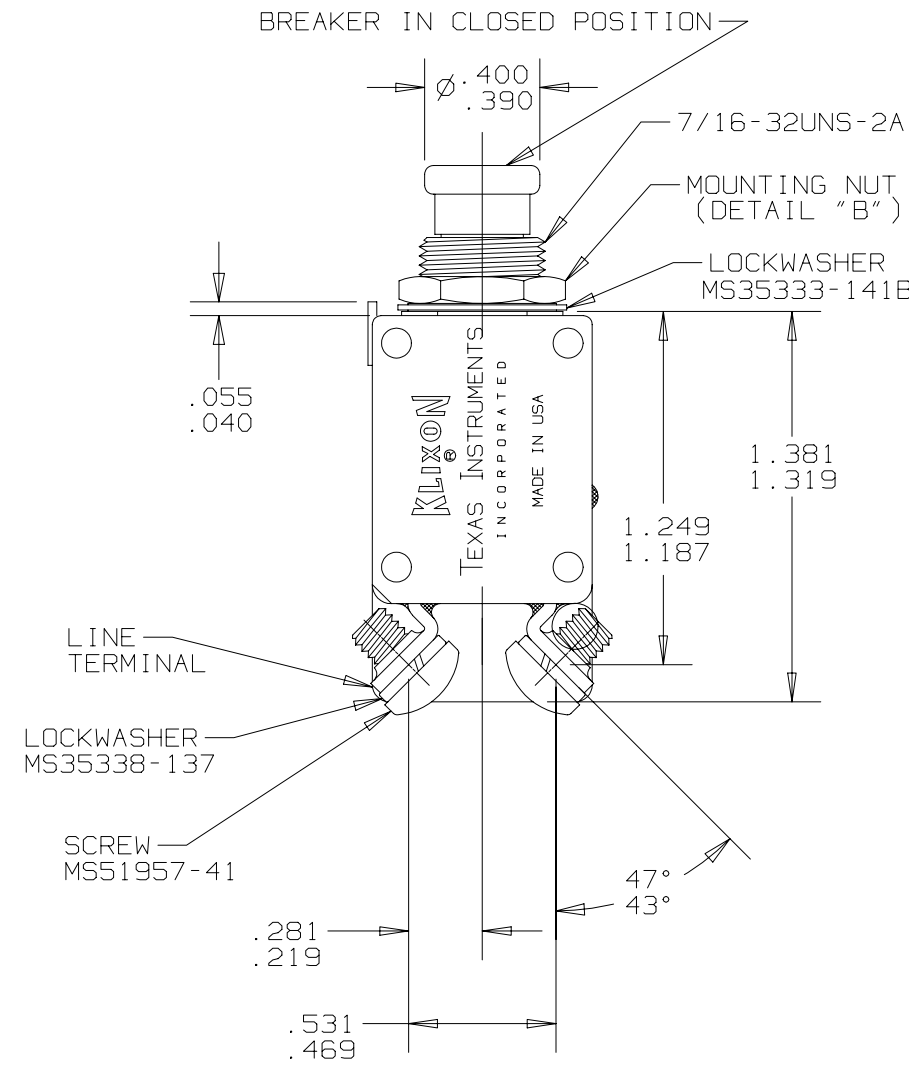

TI PART NO.	CUSTOMER PART NO.
6TC37-20	MS14154-20L
6TC37-15	MS14154-15L
6TC37-10	MS14154-10L
6TC37-7 1/2	MS14154-7 1/2L
6TC37-5	MS14154-5L
6TC37-4	MS14154-4L
6TC37-3	MS14154-3L
6TC37-2 1/2	MS14154-2 1/2L
6TC37-2	MS14154-2L

UNLESS OTHERWISE SPECIFIED DIMENSIONS ARE IN INCHES		DRAWN CHAS. FLEURANT	DATE 4-6-94	TEXAS INSTRUMENTS ATTLEBORO, MASSACHUSETTS 02703	CONTROL PRODUCTS DIVISION
TOLERANCE ON FRACTIONS DECIMALS ANGLES		ENGINEER J.R. FOWLER	4-6-94		
MATERIAL		APPROVED		TITLE PART NO: 6TC37 AMBIENT COMPENSATED CIRCUIT BREAKER PUSH-PULL, TRIP FREE ENVELOPE DRAWING	
		APPROVED		SIZE	CODE IDENT NO.
		SIGNATURES ON FILE. REFER TO ELECTRONIC CHANGE NOTICE.		C	82647
				SCALE: 4X	SHEET 1 OF 1

D

C

B

A