

4344 Series Hermetically Sealed Thermostat

Commercial

- Snap-action switching
- Rapid thermal response
- Single pole, single throw
- Normally open or normally closed
- Pre-set, non-adjustable calibration
- Various mounting configurations available
- UL recognized, file #34618, see page 36 for details
- CSA recognized, file #LR24458, see page 36 for details

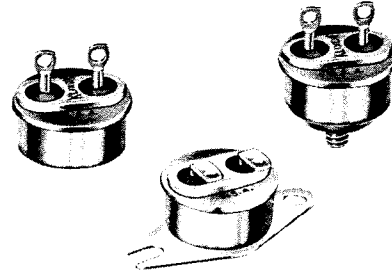

Description

The Klixon 4344 precision thermostat is constructed with a snap-acting bi-metal disc which serves as the actuating element. As the temperature reaches a predetermined calibration point, the disc snaps to its reverse curvature producing the crisp, positive switching action inherent to Klixon thermostats. This feature assures reliable, consistent operating temperature over long cycle life. The standard thermostat is copper-nickel plated with silver contacts. Other plating finishes are available upon request. Gold plated contacts can be furnished for the electrical loads listed in the following table to assure reliable circuit switching under low wattage conditions. Gold plated contacts are not suitable for higher loads.

Gold Contact Ratings (Resistive)

30 VAC/DC	500 mA and below
115 VAC	200 mA and below
230 VAC	100 mA and below

Our most common mounting configurations are depicted. Many other varieties are available.

Leads can be welded to pin type terminals to form an integral unit.

The switch can be custom packaged into a probe, strap mount, or immersion thermostat. Consult the factory for special requests.

Switching Action

All thermostats are supplied with single pole, single throw switching. The contacts can be constructed as:

Normally closed - limit type application; contacts open on temperature rise at a pre-determined temperature to de-energize the circuit. Contacts automatically re-close as the device cools to a pre-determined temperature.

Normally open - fan type application; contacts close on temperature rise at a pre-determined temperature to energize the circuit. Contacts automatically re-open as the device cools to a pre-determined temperature.

The opening and closing temperatures are pre-set and non-adjustable.

Typical Cross Section View

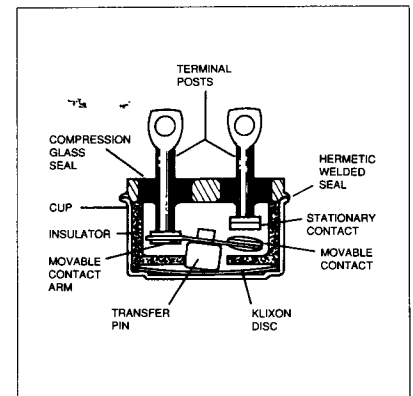

Operation

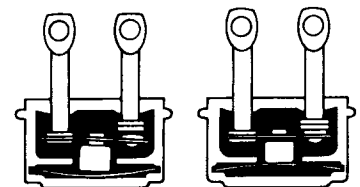

Open

Close

When heated, the internal stresses of the bi-metal cause the disc to reverse its curvature with a snap-action at a fixed, preset temperature and operate the electrical contacts.

A decrease in the ambient temperature below the reset temperature of the disc relieves the internal stresses in the disc. The disc returns to its normal curvature and the contacts assume their normal operating position.

Performance Characteristics

Switch Action

SPST (snap-action)

Contact Resistance

0.050 ohms maximum
per MIL-STD-202, Method 307

Contact Ratings (Resistive)

30 VAC/DC	125 VAC	250VAC	Life Cycles
Amperes			
5.0	2.5	1.0	100,000
5.5	3.0	1.5	50,000
6.0	4.0	2.0	25,000
6.5	5.0	2.5	10,000
7.0	6.0	3.0	5,000

Based on standard differential

Dielectric Strength

1250 VAC, rms,
60 Cycles for 1 minute,
terminal to case,
per MIL-STD-202, Method 301

Vibration Resistance

5-2000 Hz, 20G,
per MIL-STD-202, Method 204,
Condition D, (unmonitored)

Shock Resistance

100G, 6 milliseconds,
per MIL-STD-202, Method 213

Hermeticity

1 X 10⁻⁵ atm cc/sec. max,
per MIL-STD-202, Method 112,
Condition C

Salt Spray

per MIL-STD-202, Method 101,
Condition B, 5% solution

Weight

Basic unit 4.8 grams
with bracket 5.9 grams

Electrical Ratings

*720 VA, 110-600 VAC, break but
not make, ungrounded cup

360 VA, 600 VAC, make and
break, ungrounded cup

125 VA Pilot Duty, 24-240 VAC,
make and break, grounded or
ungrounded cup

* At this rating, suitable as a control circuit,
temperature limiting device for hazardous
location motors and generators.

Temperature (Use table below for common operating temperatures).

Ambient Temperature Range:

-80°F to +550°F, (-62.2°C to 287.8°C)

Maximum ambient exposure while in the closed contact position is 200°F
above contact closing temperature.

Operating temperature

Temperature at which normally closed contacts open or normally open
contacts close.

Tolerance

Allowable range above and below setpoint and reset temperatures.

Differential

Subtract the differential from the operating temperature to determine the
temperature at which the contacts will return to the normal position
(reset temperature).

Operating Temperature		Differential		Tolerance*	
°F	°C	°F	°C	±°F	±°C
-65	-53.9	30	16.7	10	5.6
-40	-40.0	30	16.7	10	5.6
-15	-26.1	30	16.7	10	5.6
0	-17.8	20	11.1	5	2.8
10	-12.2	20	11.1	5	2.8
20	-6.7	20	11.1	5	2.8
30	-1.1	20	11.1	5	2.8
40	4.4	20	11.1	5	2.8
50	10.0	20	11.1	5	2.8
60	15.6	20	11.1	5	2.8
70	21.1	20	11.1	5	2.8
80	26.7	20	11.1	5	2.8
90	32.2	20	11.1	5	2.8
100	37.8	20	11.1	5	2.8
110	43.3	20	11.1	5	2.8
120	48.9	20	11.1	5	2.8
130	54.4	20	11.1	5	2.8
140	60.0	20	11.1	5	2.8
150	65.6	20	11.1	5	2.8
160	71.1	20	11.1	5	2.8
170	76.7	20	11.1	5	2.8
180	82.2	20	11.1	5	2.9
190	87.8	20	11.1	5	2.8
200	93.3	20	11.1	5	2.8

Operating Temperature		Differential		Tolerance*	
°F	°C	°F	°C	±°F	±°C
210	98.9	30	16.7	8	4.4
220	104.4	30	16.7	8	4.4
230	110.0	30	16.7	8	4.4
240	115.6	30	16.7	8	4.4
250	121.1	30	16.7	8	4.4
260	126.7	30	16.7	8	4.4
270	132.2	30	16.7	8	4.4
280	137.8	30	16.7	8	4.4
290	143.3	30	16.7	8	4.4
300	148.9	30	16.7	8	4.4
310	154.4	40	22.2	12	6.7
320	160.0	40	22.2	12	6.7
330	165.6	40	22.2	12	6.7
340	171.1	40	22.2	12	6.7
350	176.7	40	22.2	12	6.7
375	190.6	40	22.2	12	6.7
400	204.4	40	22.2	12	6.7
425	218.3	40	22.2	12	6.7
450	232.2	40	22.2	12	6.7
475	246.1	70	38.9	25	13.9
500	260.0	70	38.9	25	13.9
525	273.9	70	38.9	25	13.9
550	287.8	70	38.9	25	13.9

Consult factory if desired operating temperature does not appear in the table.

* An additional ±3°F tolerance is required for overmolded devices.

Qualifications

UL/CSA recognition
see page 36 for details.

Plating

Copper-nickel
(other finishes available upon request)

Common Mounting Configurations

Commercial

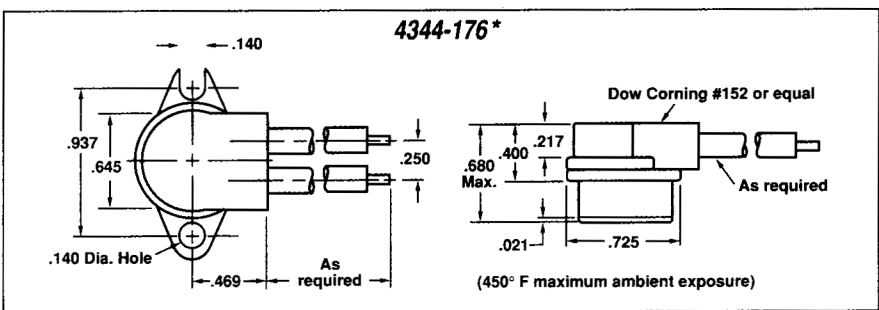
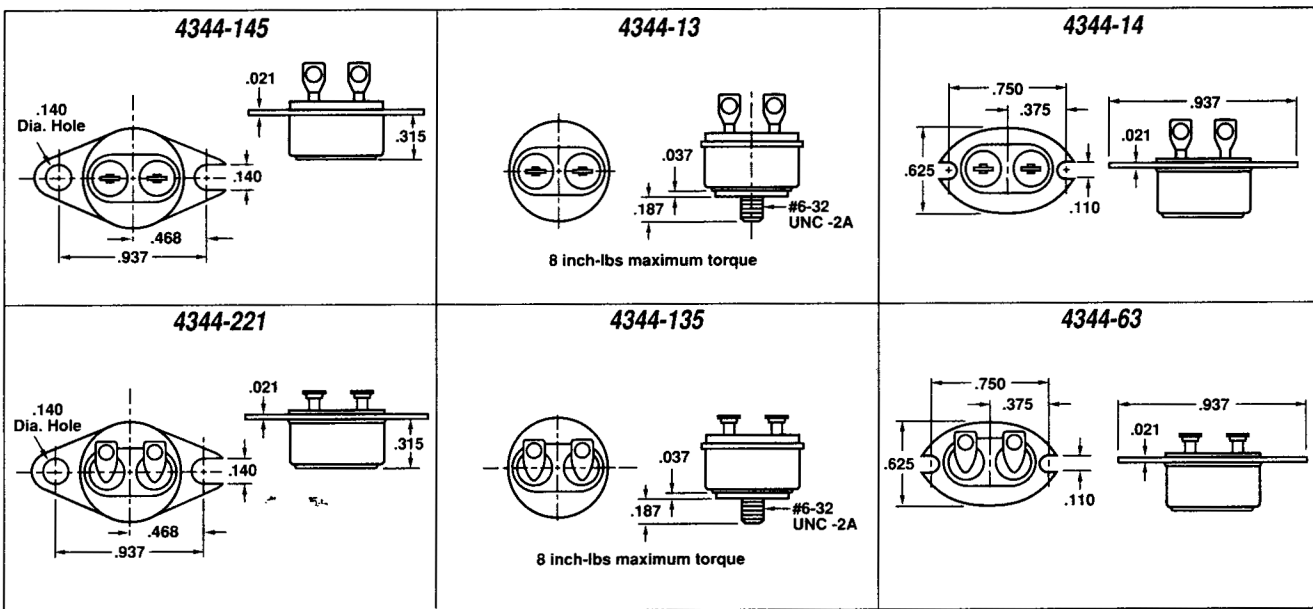
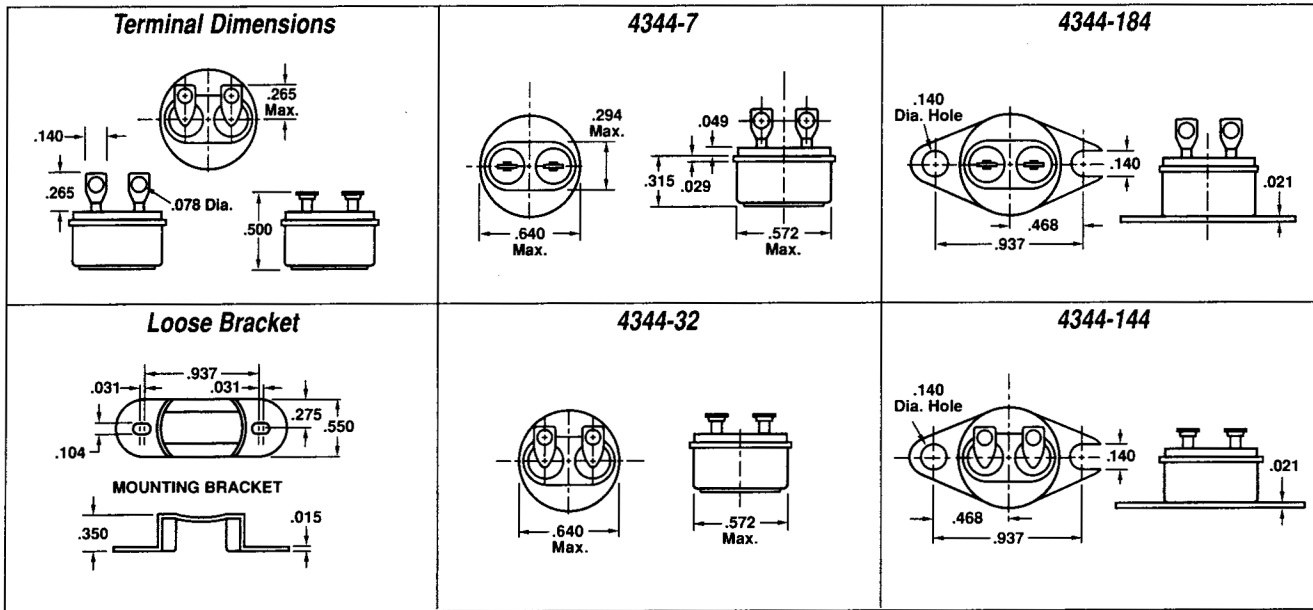

Line terminal is marked for grounded AC line voltage applications.

Dimensions are in inches.

* An additional $\pm 3^\circ\text{F}$ tolerance is required for overmolded devices.

Standard Lead Connections

Leads are available in heat-resistant rubber, neoprene, silicone-rubber and Teflon* in #18 gauge stranded wire in standard incremental lengths of 4" to 36".

Other gauges and lengths available upon request.

* Trademark of E.I. DuPont de Nemours and Co.