

4

3

2

1

REVISIONS

ZONE	LTR	DESCRIPTION	DATE	APPROVED

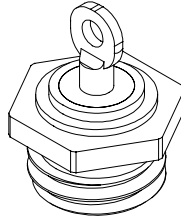
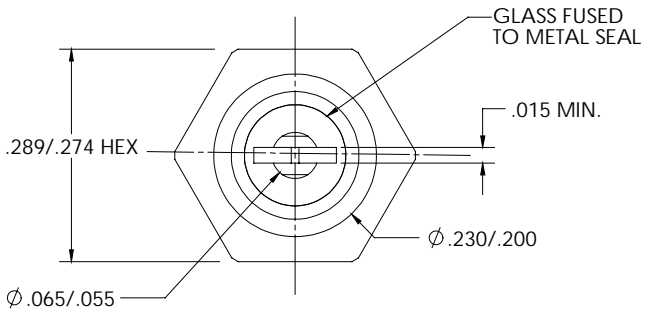

NOTES:

PART NO. 3BTL3-*.**
 PART NO. 3BTF3-*.**

"L" DESIGNATES OPEN ON TEMPERATURE RISE
 "F" DESIGNATES CLOSE ON TEMPERATURE RISE

* WHEN CUSTOMER'S TEMPERATURE CHARACTERISTICS ARE ESTABLISHED, A DASH NO. WILL BE ASSIGNED, THEREBY COMPLETING THE PART NO.

** IF WIRE LEADS ARE REQUIRED, A SECOND DASH NO. WILL BE ASSIGNED TO THE COMPLETED PART NO. THEREBY COMPLETING THE PART NO.

NOTE:

1) TERMINAL FLAT MAY BE AT A RANDOM ORIENTATION WITH RESPECT TO THE CUP TAB CENTERLINE.

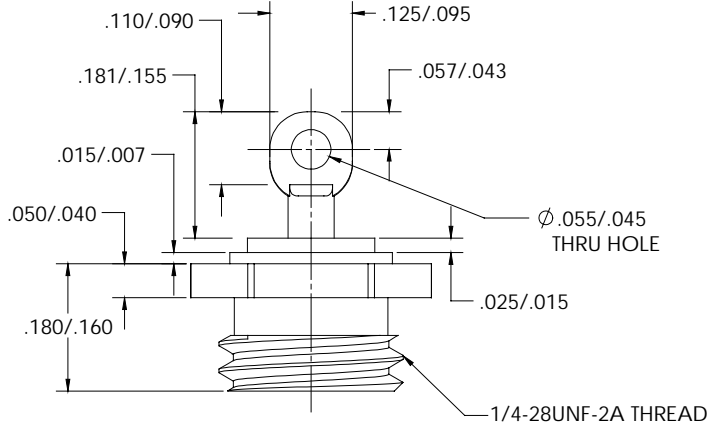

NEITHER THIS PRINT NOR THE INFORMATION CONTAINED THEREON IS TO BE USED AGAINST THE INTEREST OF TEXAS INSTRUMENTS, INC. OR AGAINST THE INTERESTS OF ANY OF ITS AFFILIATED COMPANIES OR WHOLLY OWNED SUBSIDIARIES.

FOR REFERENCE ONLY CONSULT TEXAS INSTRUMENTS CUSTOMER SERVICE FOR LATEST REVISION BEFORE USE

UNLESS OTHERWISE SPECIFIED DIMENSIONS ARE IN INCHES				DRAWN S. MARQUIS		DATE 3/25/02		TEXAS INSTRUMENTS ATILEBORO MA 02705		KILIKON CONTROL PRODUCTS DIVISION	
TOLERANCES ON FRACTIONS DECIMALS ANGLES				ENGINEER		APPROVED		TITLE		THERMOSTAT SWITCH ENVELOPE DRAWING	
MATERIAL				APPROVED		APPROVED		SIZE B		CODE IDENT NO. 82647	
SIGNATURES ON FILE. REFER TO ELECTRONIC CHANGE NOTICE.				SCALE		SHEET		82647		3BT-3 STYLE	

4

3

2

1

D

C

B

A

D

C

B

A